

EPC9528

dsPIC33CK Controller Module

Quick Start Guide

Revision 3.0

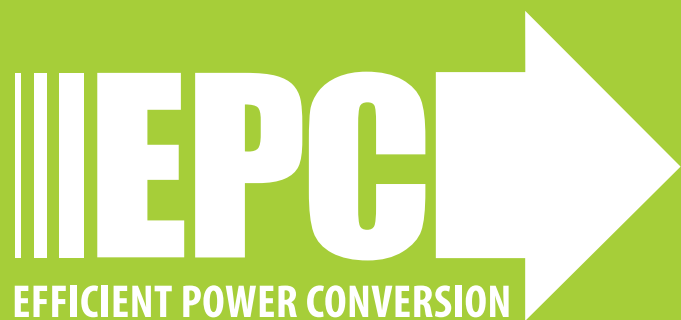

Table 4: Pin Mapping

EPC9528 J10		dsPIC33CK256MP503	
Pin #	Pin name	Pin #	Pin name
2	PWMH3	33*	TMS/RP42/PWM3H/RB10
4	PWML3	34*	TCK/RP43/PWM3L/RB11
6	PWMH2	35*	TDI/RP44/PWM2H/RB12
8	PWML2	36*	RP45/PWM2L/RB13
10	PWMH1	1*	RP46/PWM1H/RB14
12	PWML1	2*	RP47/PWM1L/RB15
14	RP38_PWMH6_SCL2	25*	PGC3/RP38/PWM6H/SCL2/RB6
Index Slot			
18	RP37_PWML6_SDA2	24*	PGD3/RP37/PWM6L/SDA2/RB5
20	RP51_RC3	16	AN15/CMP2A/IBIAS2/RP51/RC3
22	AN10_RP40	27	PGD1/AN10/RP40/SCL1/RB8
24	AN3	8	DACOUT1/AN3/CMP1C/RA3
26	AN11	28	PGC1/AN11/RP41/SDA1/RB9
28	AN14_OA3IN+	13	OA3IN+/AN14/CMP2B/ISRC1/RP50/RC2
30	AN13_OA3IN-	12	OA3IN-/AN13/CMP1B/ISRC0/RP49/RC1
32	AN1	19	OA2OUT/AN1/AN7/ANA0/CMP1D/CMP2D/ CMP3D/RP34/SCL3/INT0/RB2
34	AN2	26	TDO/AN2/CMP3A/RP39/SDA3/RB7
36	AN9_OA1IN+	7	OA1IN+/AN9/RA2
37	RP33_RB1	18	OSCO/CLKO/AN6/RP33/RB1
38	RA1_OA1IN-	6	OA1IN-/ANA1/RA1
39	RP32_RB0	17	OSCI/CLKI/AN5/RP32/RB0
40	AN12	4	AN12/ANN0/RP48/RC0
1, 3, 5, 7, 17, 19, 21, 23, 25, 27, 29, 31, 33, 35	GND	11, 15, 22, 31	AV_{SS}, V_{SS}
9, 11, 13	3V3	14, 23, 32	V_{DD}

*5 V_{DC} tolerant. Refer to dsPIC33CK256MP508 family datasheet for detail

Table 5: Programming Port

EPC9528 J20		dsPIC33CK256MP503	
Pin #	Pin name	Pin #	Pin name
1	MCLR	3	MCLR
2	3V3	14,23,32	V_{DD}
3	GND	11, 15, 22, 31	AV_{SS}, V_{SS}
4	PGD	20	PGD2/OA2IN-/AN8/RP35/RB3
5	PGC	21	PGC2/OA2IN+/RP36/RB4

*5 V_{DC} tolerant. Refer to dsPIC33CK256MP508 family datasheet for detail

Table 6: External I²C Port

EPC9528 J30		dsPIC33CK256MP503	
Pin #	Pin name	Pin #	Pin name
1	SCL	30*	RP53/PWM5L/ASCL2/RC5
2	GND	11, 15, 22, 31	AV_{SS}, V_{SS}
3	SDA	29*	RP52/PWM5H/ASDA2/RC4
4	GND	11, 15, 22, 31	AV_{SS}, V_{SS}
5	3V3	14, 23, 32	V_{DD}

*5 V_{DC} tolerant. Refer to dsPIC33CK256MP508 family datasheet for detail

OPERATING CONSIDERATIONS

3.3 V Supply

This controller module requires external 3.3 V, typically provided by the power module through the main connector J10.

Example Application Pin Assignment Maps

The on-board micro-USB port is isolated, and only provides power to the isolated side of the USB interface. It does not provide 3.3 V. By default, the MCP2221A with AduM1201 are configured as USB-UART interface.

The USB interface is routed to RP35 (TX) and RP36 (RX), as shown in Figure x.

To change the USB-UART interface to USB-I2C, please follow the instructions on the schematic.

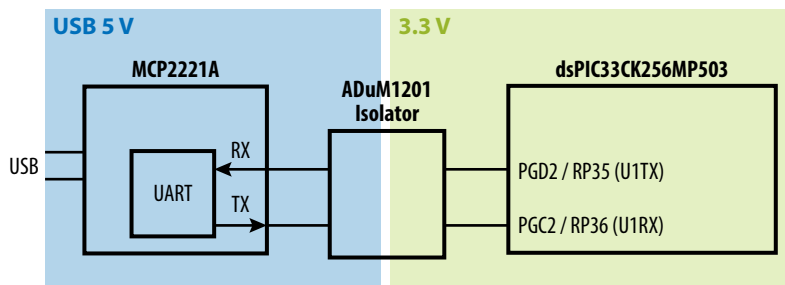

Figure 2: Micro-USB interface connection and power diagram

EXAMPLE APPLICATION PIN ASSIGNMENT MAPS

Table 7: Three-phase motor drive

Pin #	Pin name	Pin #	Pin #
2	PWMH1	VSS	1
4	PWML1	VSS	3
6	PWMH2	VSS	5
8	PWML2	VSS	7
10	PWMH3	VDD	9
12	PWML3	VDD	11
14	EncA	VDD	13
Index Slot			
18	EncB	VSS	17
20	Encl	VSS	19
22	Vin	VSS	21
24	V1	VSS	23
26	V2	VSS	25
28	V3	VSS	27
30	lin	VSS	29
32	I1	VSS	31
34	I2	VSS	33
36	I3	VSS	35
38	EN/Pgood	LEDerr	37
40	Tsns	LEDact	39

Table 8: Four-phase DC-DC converter

Pin #	Pin name	Pin #	Pin #
2	PWMH3	VSS	1
4	PWML3	VSS	3
6	PWMH4	VSS	5
8	PWML4	VSS	7
10	PWMH1	VDD	9
12	PWML1	VDD	11
14	PWMH2	VDD	13
Index Slot			
18	PWML2	VSS	17
20	Vin2	VSS	19
22	Vin1	VSS	21
24	Vout2	VSS	23
26	Vout1	VSS	25
28	lout3	VSS	27
30	lout4	VSS	29
32	lout1	VSS	31
34	lout2	VSS	33
36	Idc2	VSS	35
38	EN/Pgood	Tsns2	37
40	Idc1	Tsns1	39

PROGRAMMING

The Microchip dsPIC33CK controller can be programmed through the 5-pin header J20. It supports all of Microchip's in-circuit programmers/debuggers, such as MPLAB® ICD4, MPLAB® REAL ICE or MPLAB® PICkit4 and previous derivatives.

Development tools can be found at: <https://www.microchip.com/development-tools>

Programming with HEX file

Download the latest MPLAB® X IPE from Microchip website and follow the five steps below:

<https://www.microchip.com/mplab/mplab-integrated-programming-environment>

1. Enable Advanced Mode:

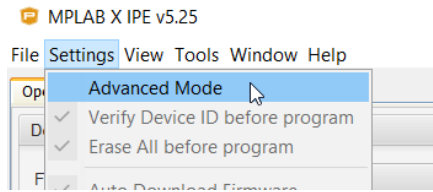

5. Erase device, and then program device:

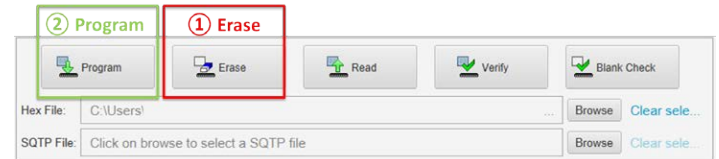

2. Select Device: dsPIC33CK256MP503 and then apply:

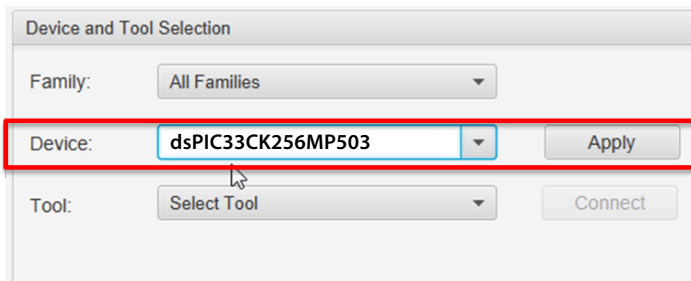

3. Select programming tool and then connect:

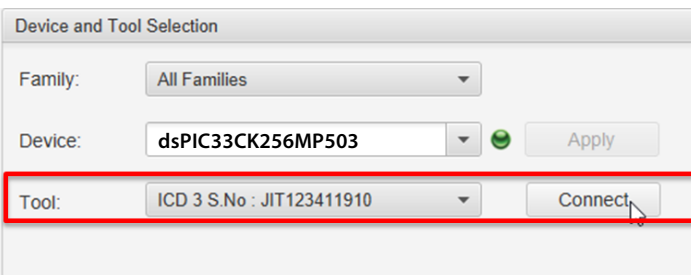

4. Click 'Browse' to select the provided .hex file:

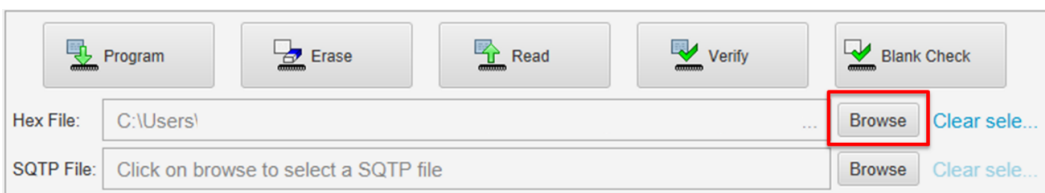

Optional:

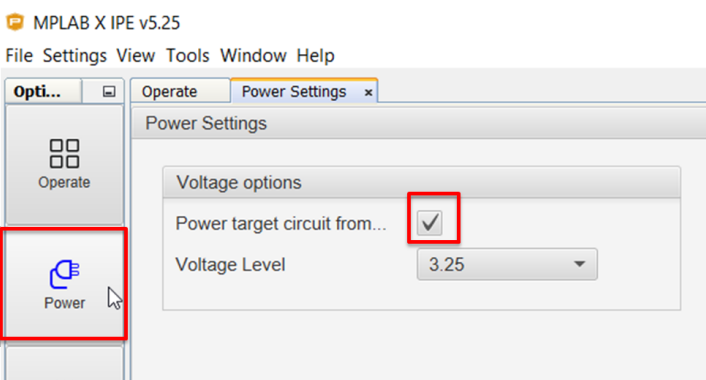

Table 9: Bill of Materials

Item	Qty	Reference	Part Description	Manufacturer	Part #
1	7	C1, C2, C3, C4, C500, C501, C520	0.1 μ F, 25 V	Yageo	CC0402KRX7R8BB104
2	1	C10	1 μ F, 25 V	Murata	GRM155R61E105MA12D
3	1	C20	56 pF, 50 V	TDK	C1005C0G1H560J050BA
4	2	C30, C31	22 μ F, 25 V X7R	Taiyo Yuden	TMK325B7226MM-TR
5	2	C35, C36	10 μ F, 25 V X5R	Murata	GRM188R61E106MA73D
6	9	C70, C71, C72, C73, C74, C75, C76, C77, C78	220 pF, 50 V	Kemet	C0402C221K5RACTU
7	2	C502, C503	47 pF, 50 V	Yegeo	CC0402JRNPO9BN470
8	1	C510	10 μ F, 10 V	TDK	C1005X7S1A105K050BC
9	1	C511	470 nF, 6V3	Murata	GRM155R60J474KE19D
10	1	D1	LED 0603 Green	Würth	150060VS75000
11	1	D2	LED 0603 Red	Würth	150060RS75000
12	1	D500	TVS Diode Array 6V	Würth	82400152
13	3	FB35, FB501, FB502	180 Ω @ 100 MHz	Murata	BLM15PX6015N1D
14	1	J20	.1" Male RA	Tyco	4-103185-0-04
15	1	J500	USB Mini	Amphenol ICC (FCI)	10118194-0001LF
16	1	L500	90 Ω 550 mA 50 V	Würth	744230900
17	2	R1, R2	261 Ω	Panasonic	ERJ-2RKF2610X
18	6	R10, R80, R81, R90, R91, R551	0 Ω	Panasonic	ERJ-3GEY0R00V
19	2	R20, R510	10 k	Yageo	RC0402FR-0710KL
20	1	R21	100 Ω 1%	Yageo	RC0402FR-07100RL
21	1	R501	4.7 k	Panasonic	ERJ-2RKF4701X
22	2	R502, R503	15 Ω	Panasonic	ERJ-2RKF15R0X
23	2	R530, R531	270 Ω	Panasonic	ERJ-2RKF2700X
24	1	U1	dsPIC	Microchip	dsPIC33CK256MP503-E/M5
25	1	U510	USB to I ² C and UART	Microchip	MCP2221A-I/ML
26	1	U520	Digital Isolator	Analog	ADuM1201CR/ADuM1250ARZ

Table 2: Optional Components

Item	Qty	Reference	Part Description	Manufacturer	Part #
1	1	J30	50 mil straight	Sullins	GRPB051VWVN-RC
2	4	R82, R83, R92, R93	15 K	Yageo	RC0603FR-0715KL
3	3	R532, R533, R552	0 Ω	Panasonic	ERJ-3GEY0R00V
4	4	R520, R521, R534, R535	4.7 k	Panasonic	ERJ-2RKF4701X

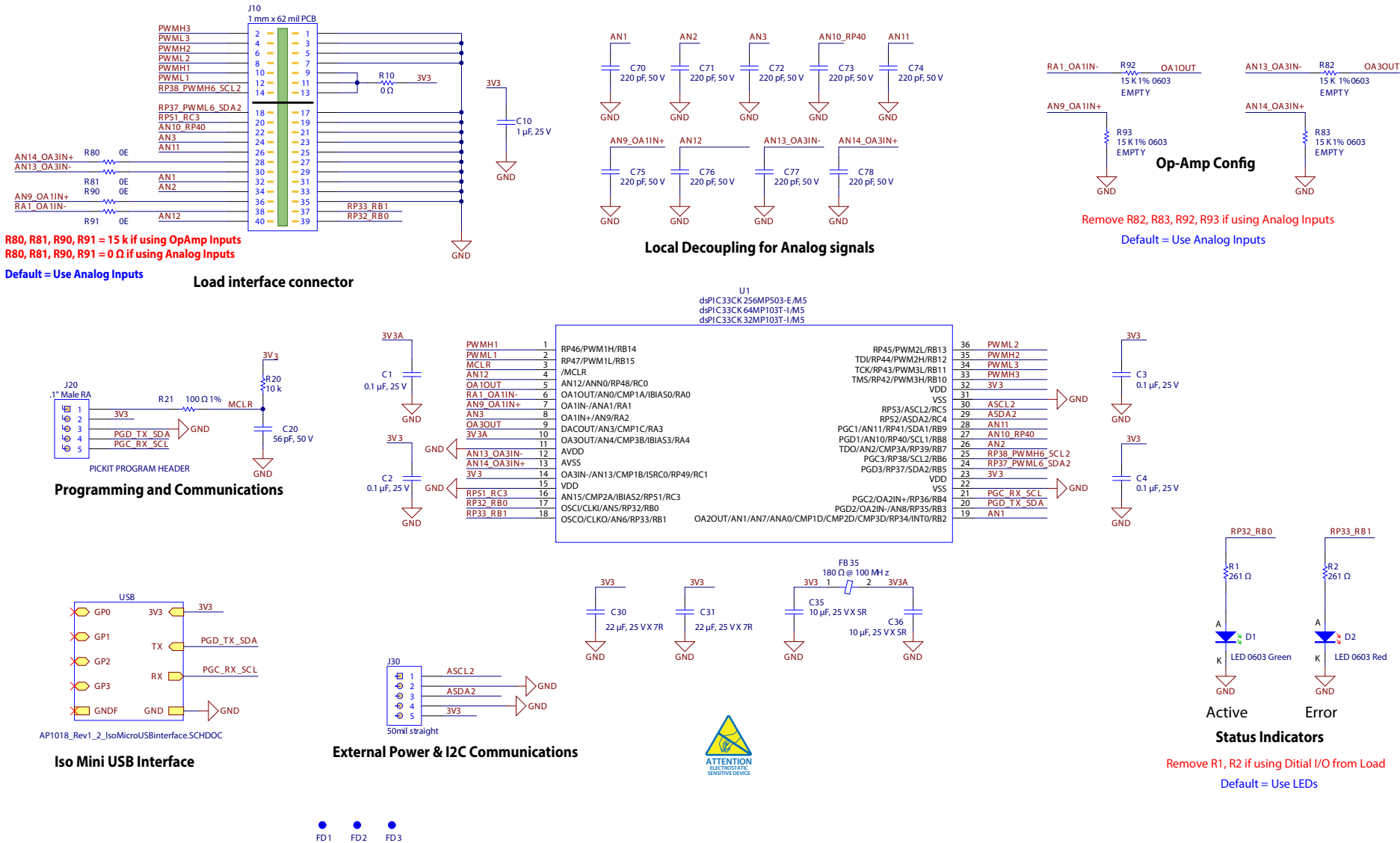

Figure 3: EPC9528 main schematic

Data type selector

Default set to UART using 5 V

UART		I ² C	
5 V		3V3	
Install	DNP	Install	DNP
R530	R532	R532	R530
R531	R533	R533	R531
R551	R534	R534	R551
	R535	R535	
	R520	R520	
	R521	R521	
	R552	R552	

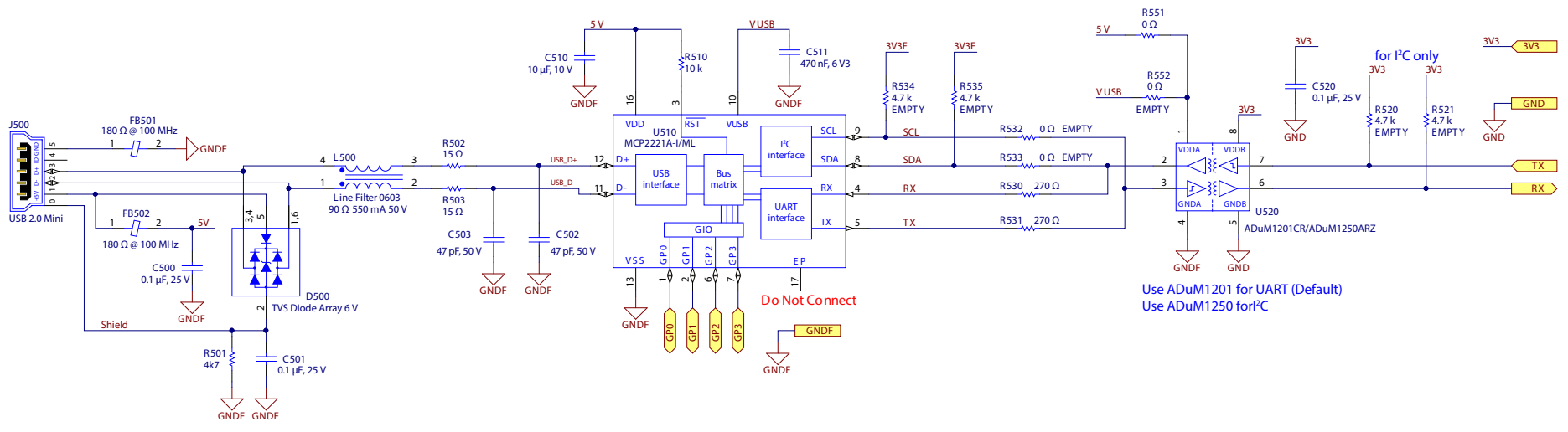

Figure 4: EPC9528 USB interface schematic



EPC would like to acknowledge Microchip Technology Inc. (www.microchip.com) for their support of this project.

Microchip Technology Incorporated is a leading provider of smart, connected and secure embedded control solutions. Its easy-to-use development tools and comprehensive product portfolio enable customers to create optimal designs, which reduce risk while lowering total system cost and time to market. The company's solutions serve customers across the industrial, automotive, consumer, aerospace and defense, communications and computing markets.

The EPC9137 system features the **dsPIC33CK256MP503** 16-Bit Digital Signal Controller with High-Speed ADC, Op Amps, Comparators and High-Resolution PWM. Learn more at www.microchip.com.

For More Information:

Please contact info@epc-co.com
or your local sales representative

Visit our website:
www.epc-co.com

Sign-up to receive
EPC updates at
bit.ly/EPCupdates
or text "EPC" to 22828



EPC Products are distributed through Digi-Key.
www.digikey.com

Demonstration Board Notification

The EPC9528 board is intended for product evaluation purposes only. It is not intended for commercial use nor is it FCC approved for resale. Replace components on the Evaluation Board only with those parts shown on the parts list (or Bill of Materials) in the Quick Start Guide. Contact an authorized EPC representative with any questions. This board is intended to be used by certified professionals, in a lab environment, following proper safety procedures. Use at your own risk.

As an evaluation tool, this board is not designed for compliance with the European Union directive on electromagnetic compatibility or any other such directives or regulations. As board builds are at times subject to product availability, it is possible that boards may contain components or assembly materials that are not RoHS compliant. Efficient Power Conversion Corporation (EPC) makes no guarantee that the purchased board is 100% RoHS compliant.

The Evaluation board (or kit) is for demonstration purposes only and neither the Board nor this Quick Start Guide constitute a sales contract or create any kind of warranty, whether express or implied, as to the applications or products involved.

Disclaimer: EPC reserves the right at any time, without notice, to make changes to any products described herein to improve reliability, function, or design. EPC does not assume any liability arising out of the application or use of any product or circuit described herein; neither does it convey any license under its patent rights, or other intellectual property whatsoever, nor the rights of others.