

Figure 10: EPC9506 Source Board Amplifier Schematic

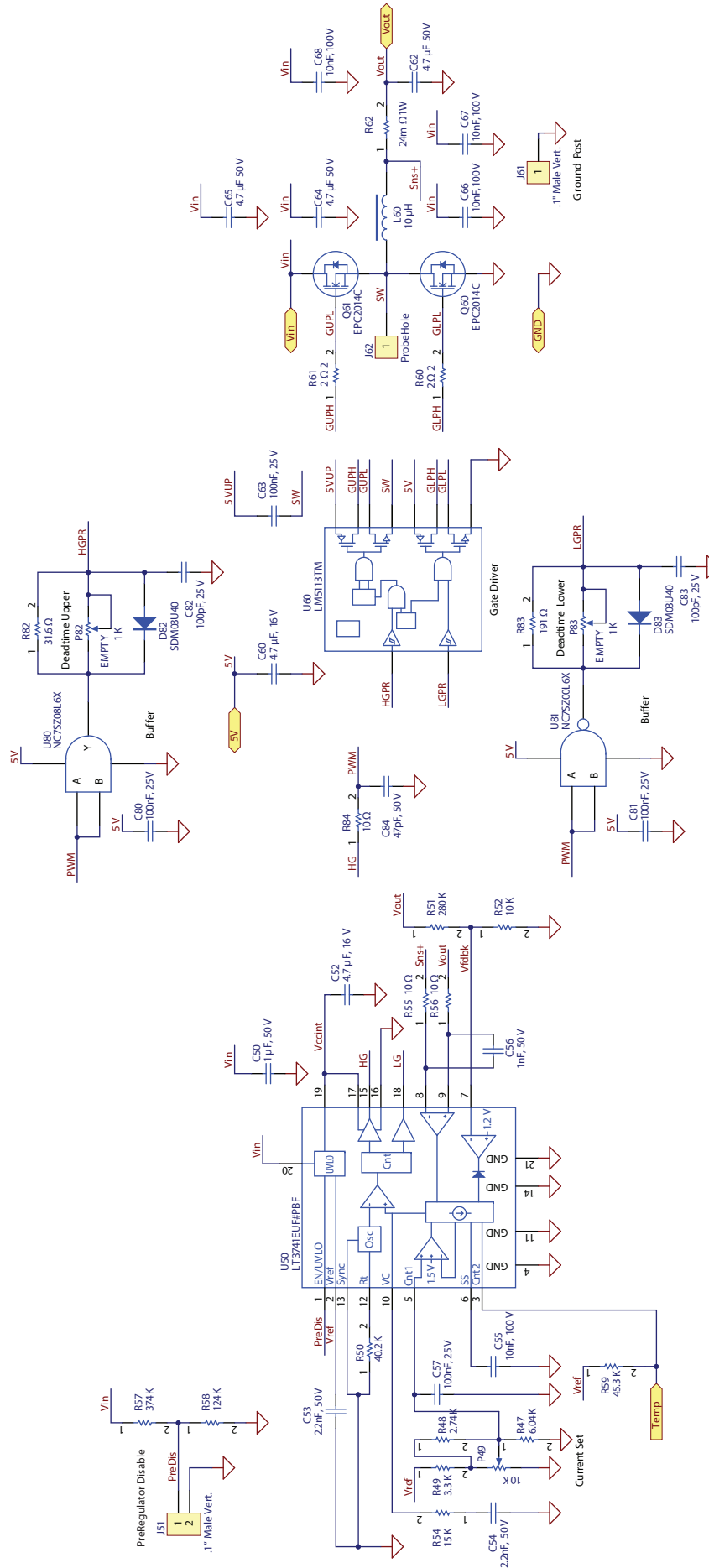

Figure 11: EPC9506 - Source Board Pre-Regulator Schematic

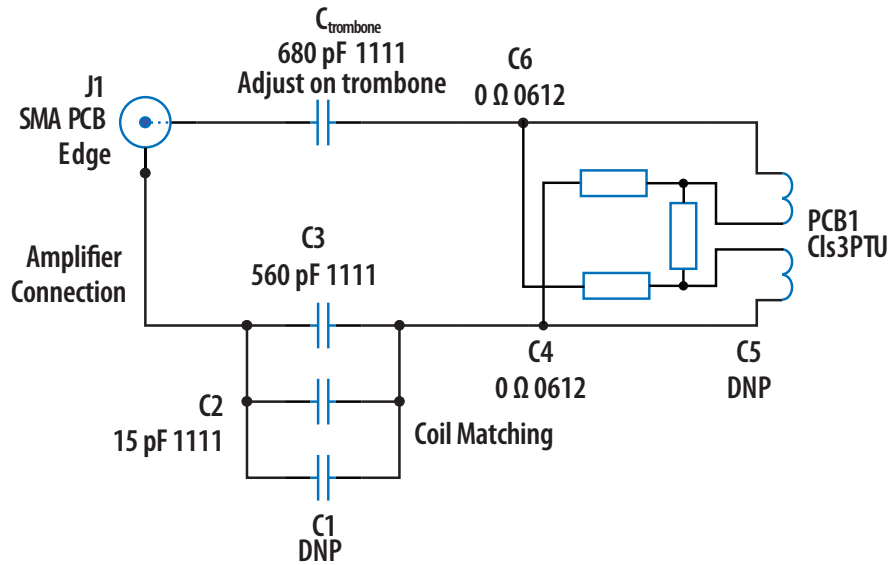

Figure 12: Class 3 Source Board Schematic

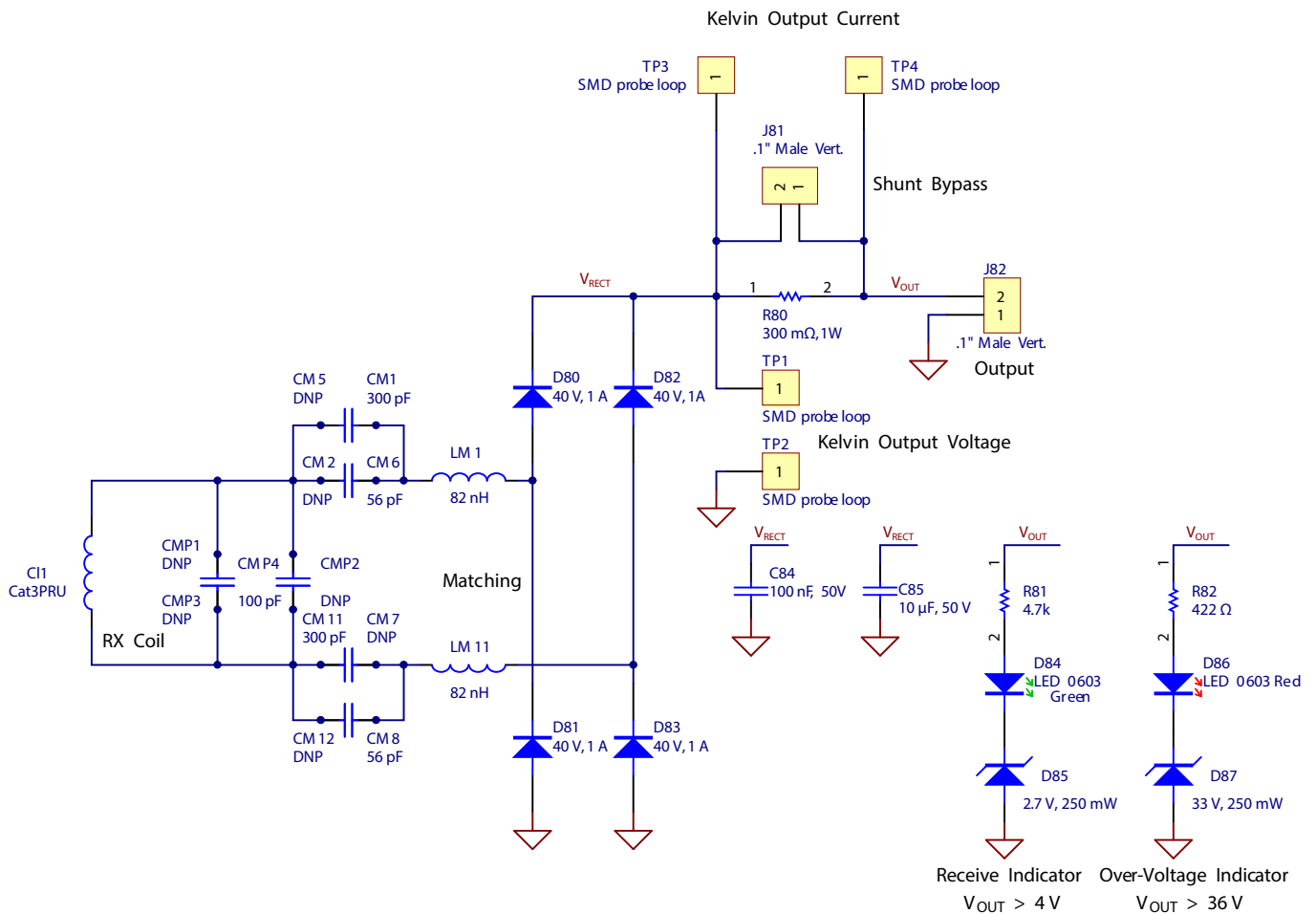

Figure 13: Category 3 Device Board Schematic